

AMCC 8

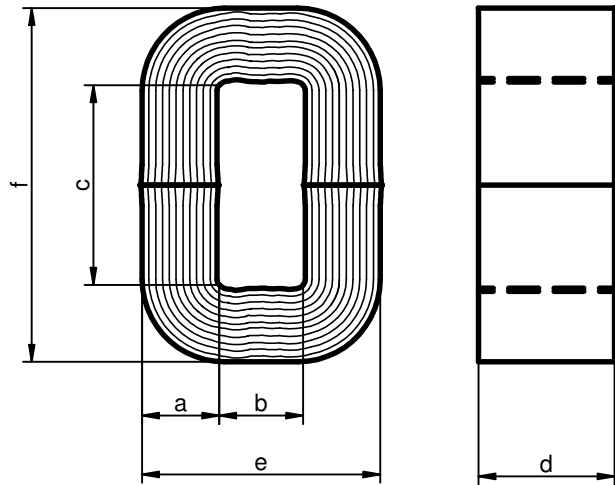

FRONT VIEW

SIDE VIEW

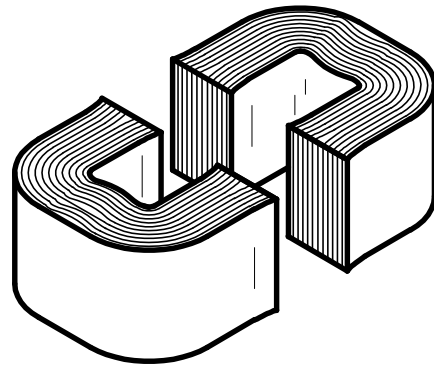

ISOMETRIC VIEW

PHYSICAL SPECIFICATIONS (mm)	CORE BUILD (a)	WINDOW WIDTH (b)	WINDOW LENGTH (c)	CORE HEIGHT (d)	CORE WIDTH (e)	CORE LENGTH (f)	WEIGHT OF CORE # (g)
		11.0	13.0	30.0	20.0	35.0	52.0
TOLERANCES (mm)	±0.8	MIN.	MIN.	±0.5	+1.0 / -0.5	+2.0 / -0.0	NOM.
# WEIGHT INCLUDES 2% (NOM.) EPOXY WEIGHT.							
CALCULATED SPECS	STACK FACTOR	MEAN MAGNETIC PATH LENGTH (lm)		NET CROSS SECTIONAL AREA (Ac)	WINDOW AREA (Wa)	AREA PRODUCT (Ap)	
	%	cm		cm ²	cm ²	cm ⁴	
	82%	13.0		1.8	3.9	7.0	
TOLERANCES	±2%	NOM.		NOM.	NOM.	NOM.	
TEST SPECIFICATIONS	CORE LOSS @ 16kHz, 0.037T						
	≤ 1.38 W / Kg						
	TOLERANCES	Max.					

- * All measurements are done at Room Temperature (22°C to 28°C).
- * Continuous Operating Temperature: 150°C (Max.)

NOTES:-

- Customer to mark dimensions/characteristics that are critical to fit/form and function on the drawing.
- Number of components to be submitted for pilot production lot=_____pieces.
- Unless otherwise specified, standard packaging used by Hitachi Metglas will be provided.
- All production records and data pertaining to this product will be retained for a period of 1 year from the date of shipment.

GENERAL INSTRUCTIONS:-

- Bare core, kept in open, is rust prone.
- Core with minor rust can be used after cleaning with suitable rust preventive chemical.
- Core to be shelf stored in proper packaging like VCI (Volatile Corrosion Inhibitor) paper cover.
- Core recommended to be used in application after suitable varnishing / coating / potting / covering etc.

SIGNATURE: _____ DATE: _____

NAME: _____

COMPANY NAME: _____

CUSTOMER APPROVAL

DISCLAIMER: The manufacturer ensures outer dimensions & weight of each individual core conforms to specifications. However, core profile & inner window dimensions are indicative & minimum dimensions are ensured.

Note :-
This drawing, the property of **Hitachi Metglas India Pvt. Ltd.**, is furnished subject to return on demand and condition that information and technology embodied herein shall not be disclosed or used and the drawing shall not be reproduced or copied in whole or in part except as previously authorized in writing. Any person who may receive or observe this design will be held strictly liable for any violation whether willful or negligent.

TOLERANCES UNLESS OTHERWISE SPECIFIED	NO.	REVISION	BY	APPR.	DATE	DIMENSIONS	mm	DESCRIPTION	NO. OF SHEET	DRAWING NO.	REV. NO.			
	1)	CORE LOSS WAS WRITTEN MEASURED @ 0.37T BY MISTAKE , INSTEAD OF 0.037T	SA	SR	19/04/02	SCALE	N.T.S	PRODUCT DRAWING - AMCC8 PRIME RAW MATERIAL METGLAS®ALLOY 2605SA1	1 OF 1	AMCC8	5			
	2)	COMPANY NAME WAS HONEYWELL.	SA	RK	14/02/04	PROJECTION								
	3)	ADDED NOTE#3. (AS PER PCN002).	SA	RK	26/07/04									
	4)	PRODUCT & DRAWING FORMAT REVISED. (AS PER PCN004)	RG	RK	25/09/06									
	5)	PRODUCT TOLERANCE & DRAWING FORMAT REVISED.(REFER PCN005)	AS	RG	16/05/08									
								 Hitachi Metglas	DRAWN	DATE	CHECKED	DATE	APPROVED	DATE
								SR	07/12/01	SR	07/12/01	RH, RM, ST	07/19/01	